

AN IDEA BECOMES A VISION. A NEW PRODUCT IS APPROVED.
AND PRODUCTION DEADLINES ARE SET.

EFFICIENCIES ARE SOUGHT. ROI HURDLES ARE DEVELOPED.
AND A PLAN OF ACTION IS DETERMINED.

In either scenario a trusted, experienced partner is required to insure success. Since its inception American Conveyor has become a trusted resource for industry. Why? Because in an increasingly, competitive economic environment, American Conveyor offers best in class solutions that are economically justifiable.

American Conveyor is a single source consultant, designer, integrator and manufacturer with a broad array of experience in the dairy, ice cream, snack food, packaged goods and industrial arena.

American Conveyor's customized solutions are a by-product of a collaborative effort between our clients and experienced engineering team. American Conveyor's experience with respect to design, layout and equipment is wide and varied. As a neutral party, we offer an unbiased opinion on manufactured components. As a custom designer and manufacturer we design and build to your project criteria.

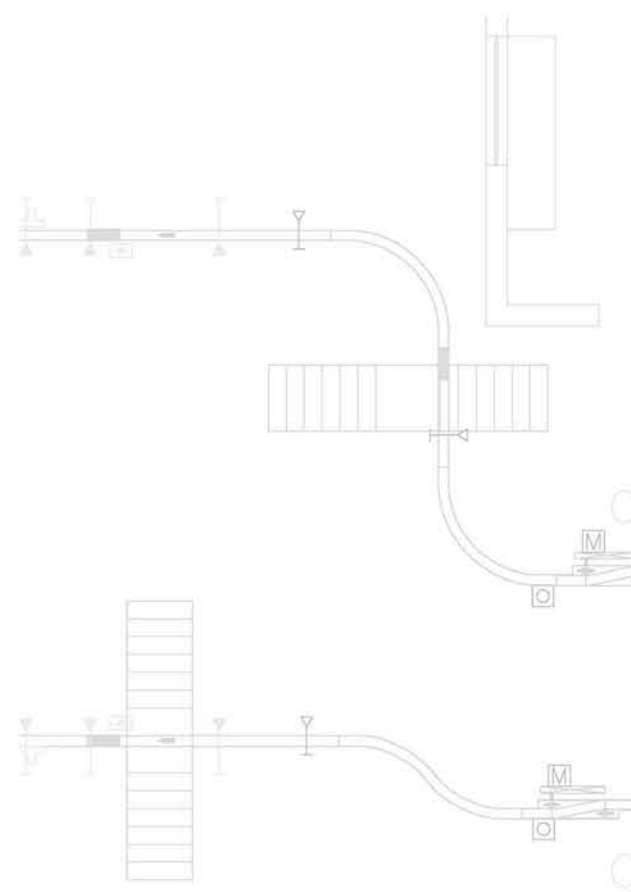

American Conveyor
Engineering productive material handling solutions since 1993

American Conveyor products and systems are designed and built for durability and longevity. Our customized solutions offer corrosion resistant stainless steel, plastic components, food grade approved materials, versatile configurations and hygienic wash down designs.

MAIN OFFICE:

NEW YORK | 1819 FLUSHING AVENUE | RIDGEWOOD, NY | 11385 | 718.386.0480
MASSACHUSETTS / FLORIDA

INTEGRATED DESIGN & MANUFACTURING SOLUTIONS
FOR FOOD & INDUSTRIAL PROCESSES

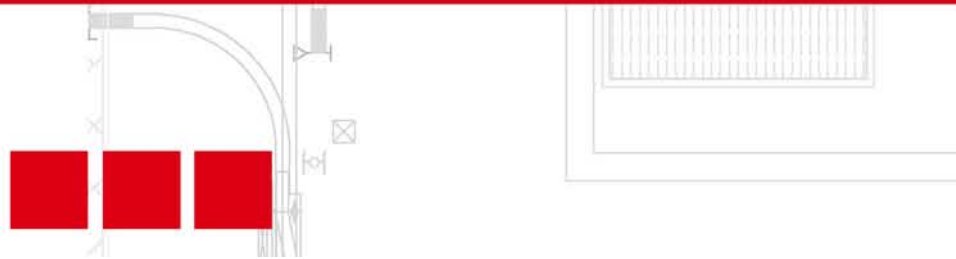
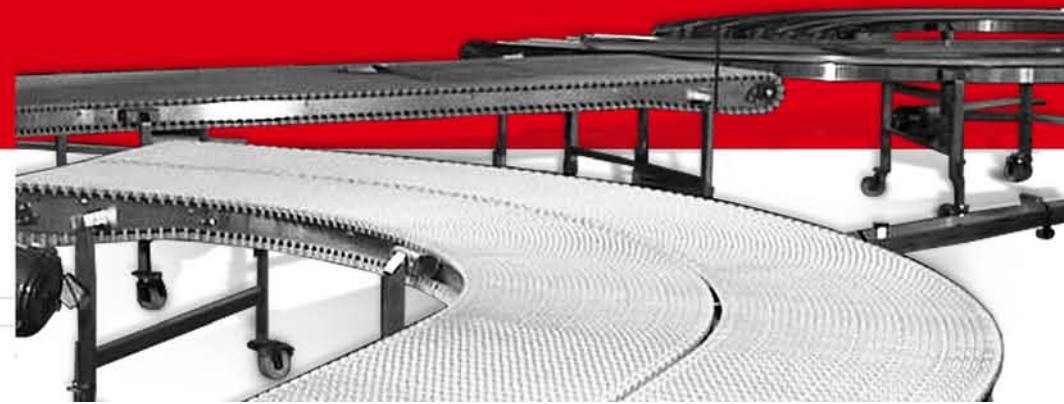

THE SYSTEMS

ELEVATION CHANGE SYSTEMS:

- Verticle Lifts
- Gripper Elevators
- Alpine Conveyors
- Incline & Decline Conveyors
- Lowerators



BOTTLE HANDLING SYSTEMS:

- Dividers
- Diverter
- Single Filers
- Loop Inverters
- Bottle Turners
- Cable Conveyors
- Combining
- Turn-Tables

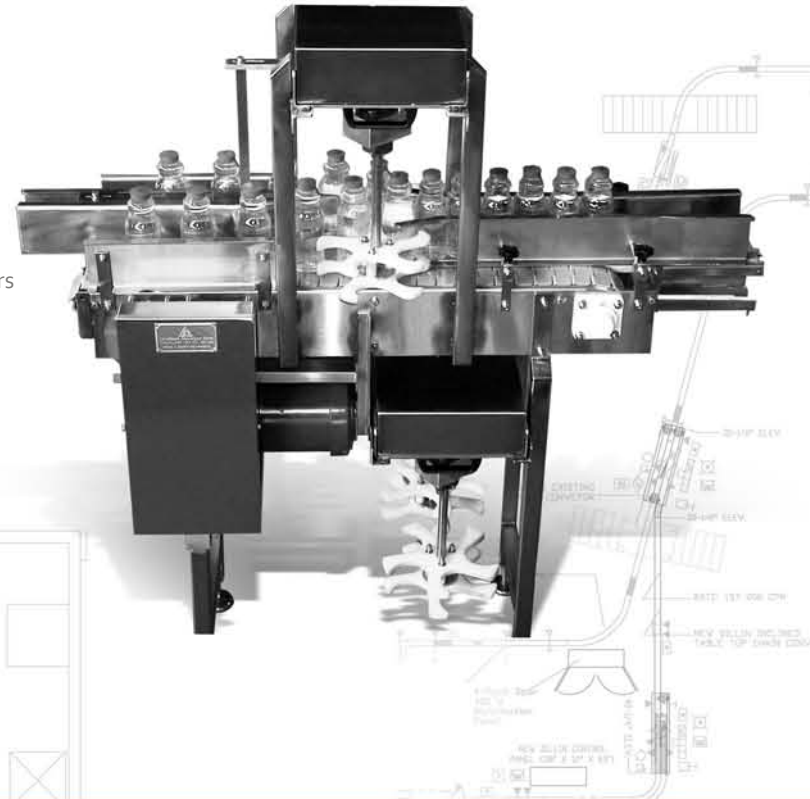

PACKAGE HANDLING SYSTEMS:

- Case Pushers
- Case Dividers
- Debaggers
- Package Turners
- Vacuum Conveyors
- Wheel Dives
- Drag Chains
- (De) Unitizers
- (De) Palletizers



ACCUMULATION SYSTEMS:

- Alpine Conveyors
- Spiral Conveyors
- In-Line Accumulation Tables
- Bi-Directional
- Mass Flow Conveyor



PRODUCT/SPECIALTY CONVEYOR SYSTEMS:

- Mat Top
- Table Top
- Pack-off
- Belt Conveyors
- Modular Belt Conveyor
- "Table-Top" Conveyor
- Pack-Off Stations

